



# *Analog*

**Power & Analog  
program**

**European  
Multi System Market  
Competence Center**

- **Standard linear**
  - Linear regulators
  - Comparators
  - Operational amplifier
  
- **Sensors**
  - Temperature
  - Proximity
  - Industrial I/O peripheral
  - MEMS

- **Standard linear**
  - **Linear regulators**
  - Comparators
  - Operational amplifier
  
- **Sensors**
  - Temperature
  - Light
  - Proximity
  - Industrial I/O peripheral
  - MEMS

# Linear regulators – product tree

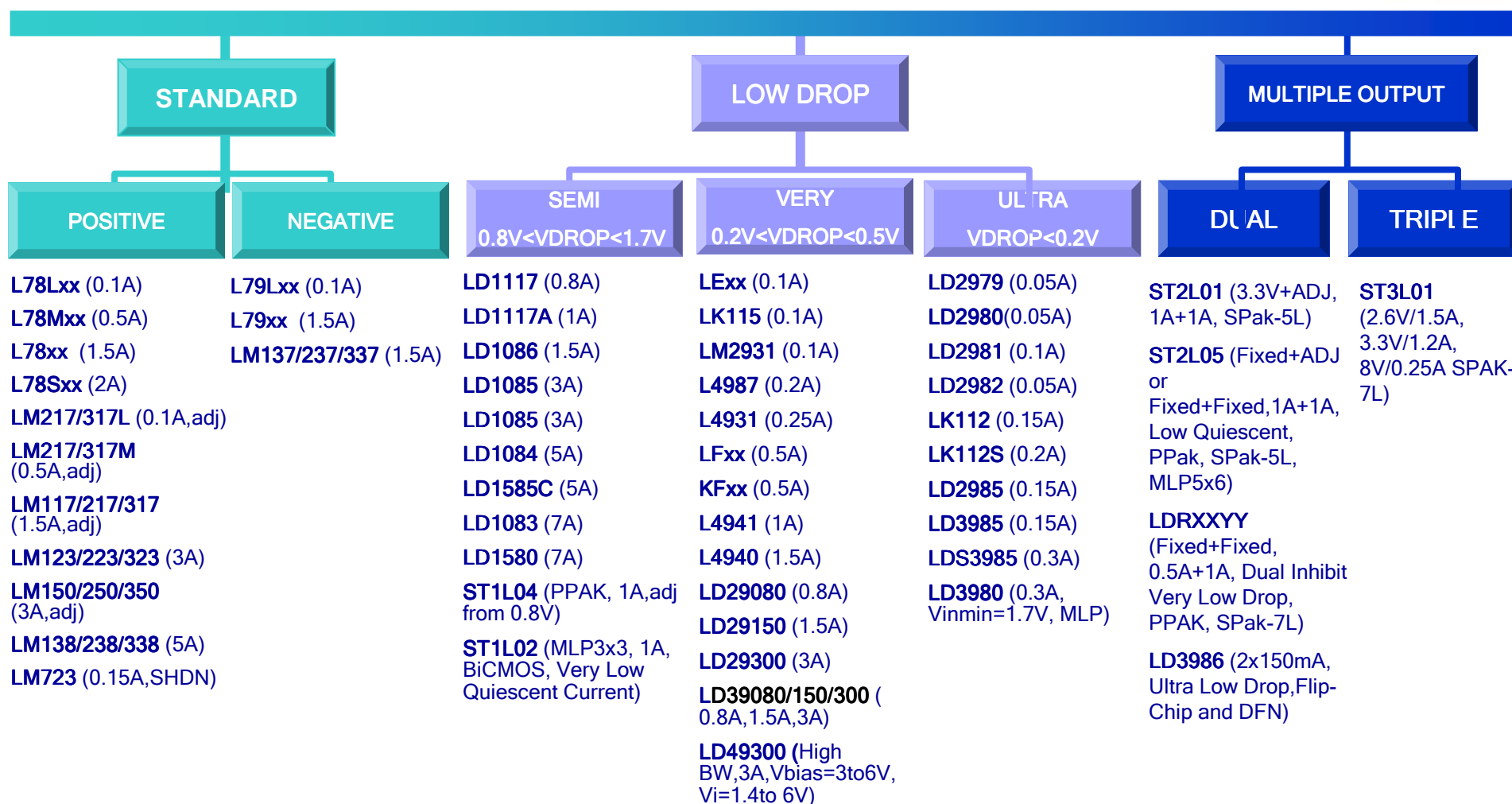

- **Standard linear**
  - Linear regulators
  - **Comparators**
  - Operational amplifier
  
- **Sensors**
  - Temperature
  - Proximity
  - Industrial I/O peripheral
  - MEMS

# Comparators – product portfolio

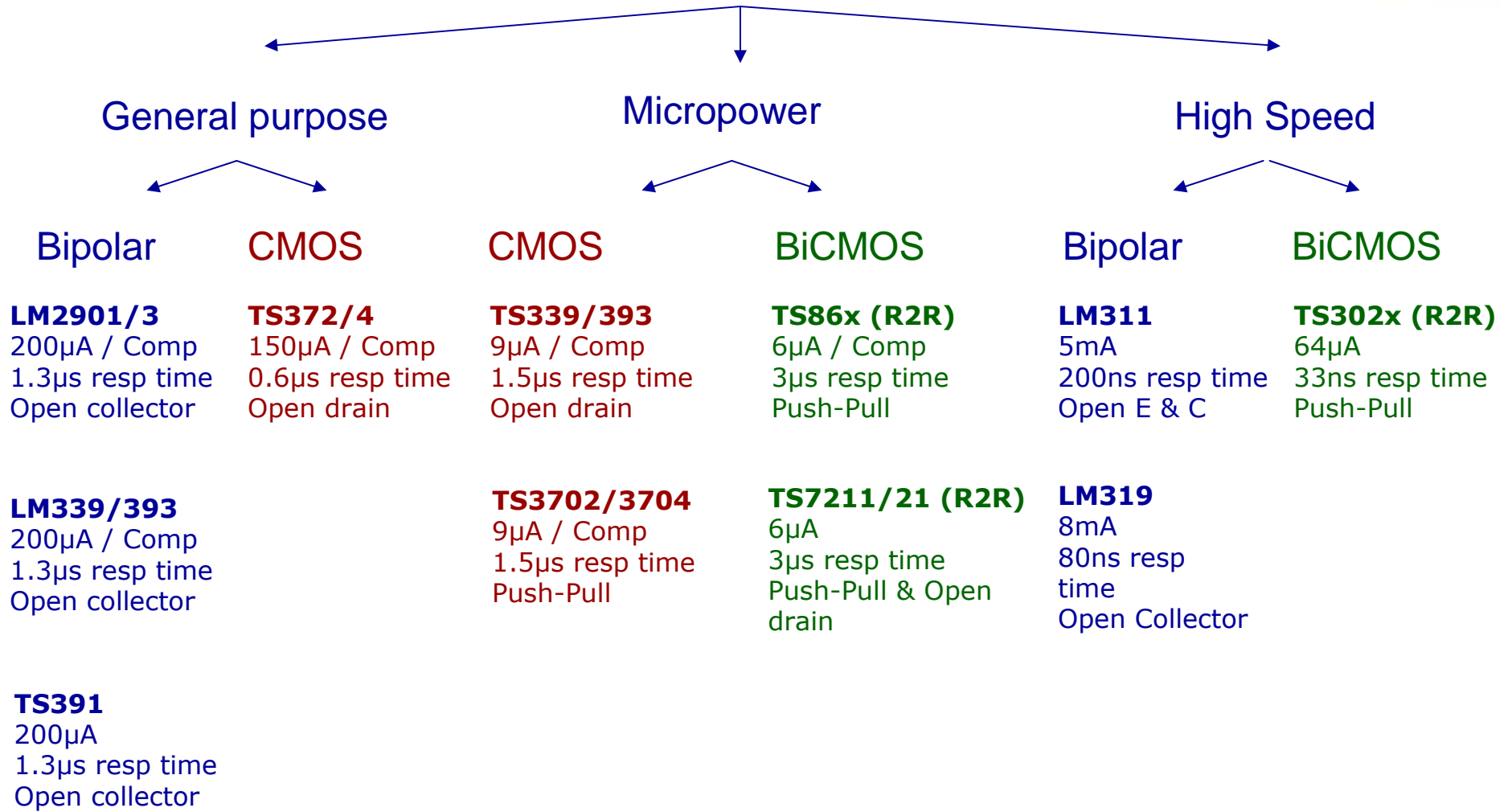

# TS3021 / 22 – rail-to-rail high speed comparator



## • PRODUCT DESCRIPTION

- **64 $\mu$ A** power consumption
- **33ns** response time
- Operating From  $V_{cc}$ = **1.8V to 5V**
- **Rail to Rail** Inputs
- Push-pull Outputs
- **TS3022 / SO8 miniSo8**

**Push  
Pull  
Output**

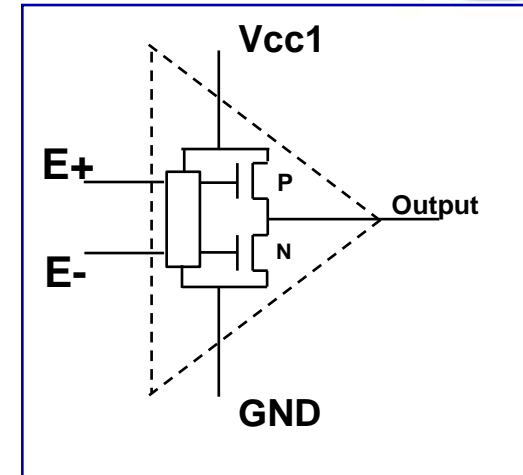

## APPLICATIONS

- Telecom
- Industrial
- Consumer

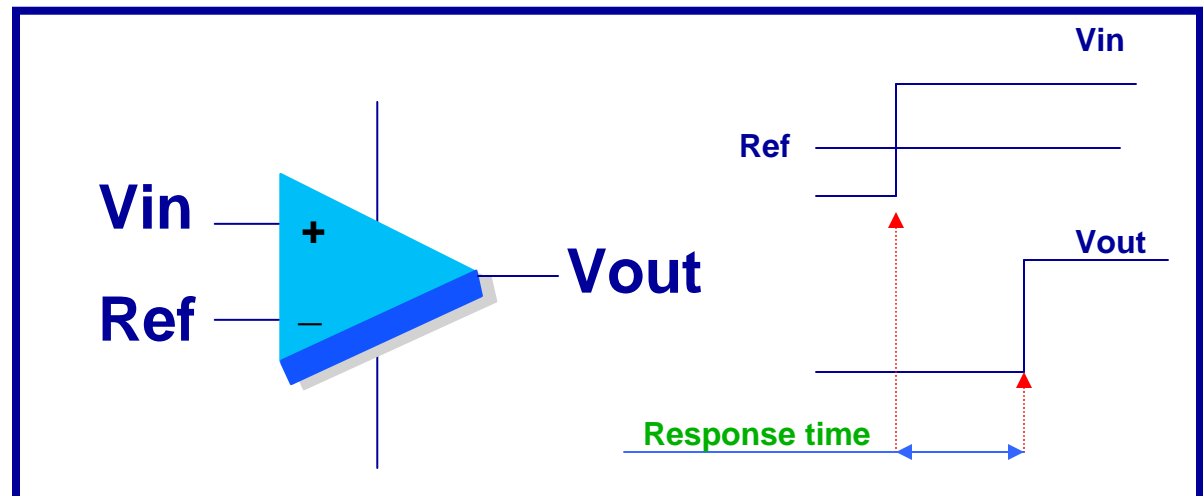

# TS86x micropower comparators



## • PRODUCT DESCRIPTION

- **6 $\mu$ A** power consumption
- **3 $\mu$ s** response time
- Operating From  $V_{cc}$ = **2.7V to 10V**
- **Rail to Rail** Inputs / Outputs
- **SOT23-5** packages for single
- **SO and TSSOP** for the dual & quad



## • APPLICATIONS

- Portable electronics
- Low voltage
- Alarms

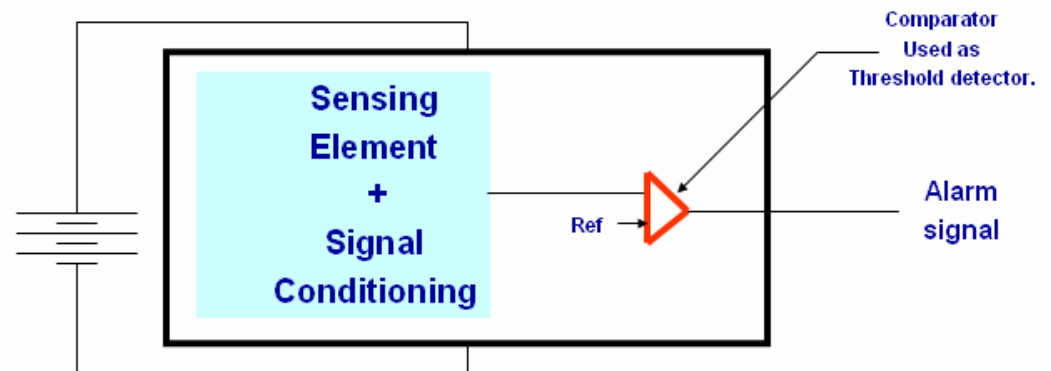

- **Standard linear**
  - Linear regulators
  - Comparators
  - **Operational amplifier**
  
- **Sensors**
  - Temperature
  - Proximity
  - Industrial I/O peripheral
  - MEMS

# Operational amplifier – used technologies

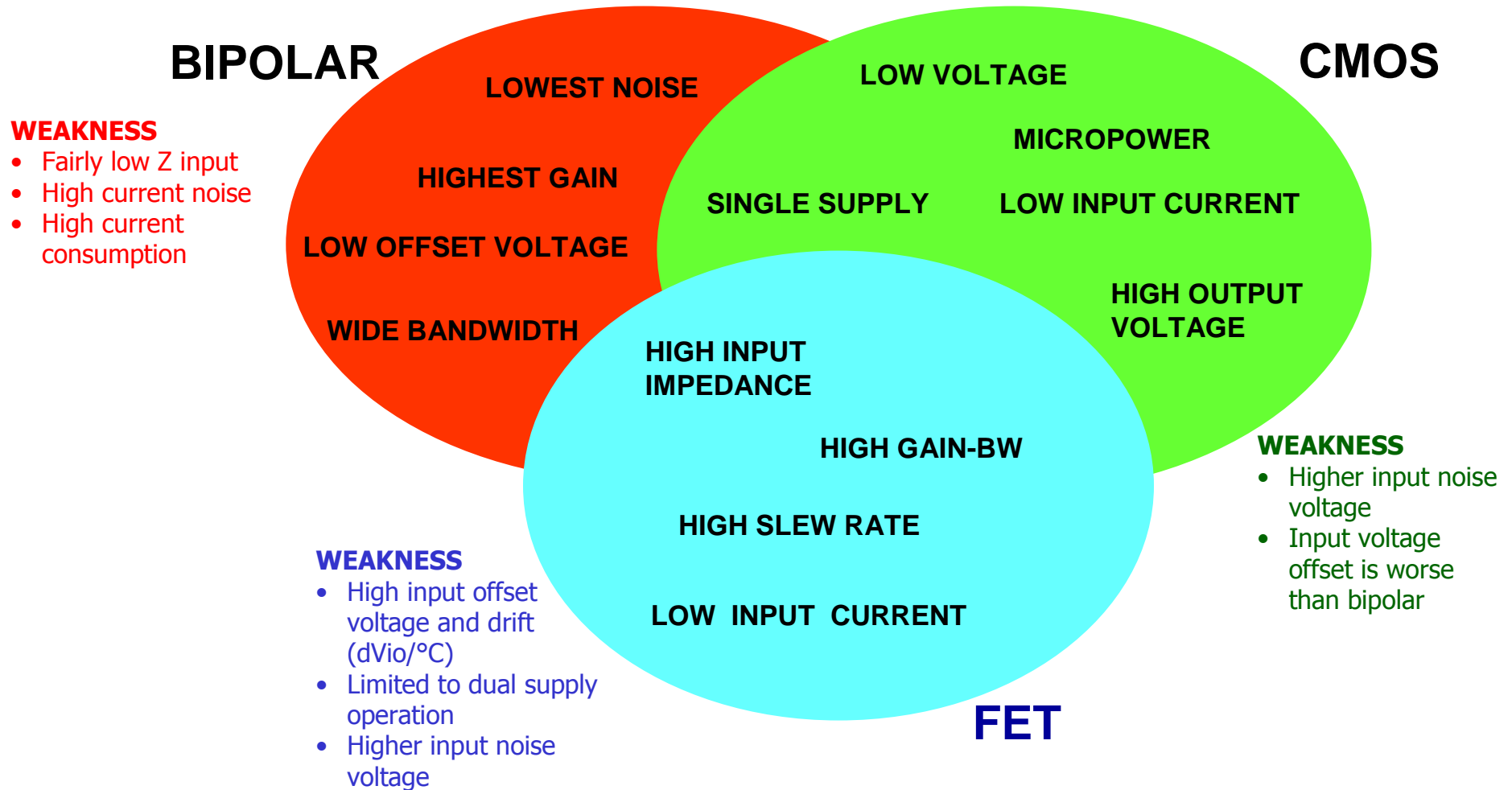

# Op-amp – new products



Op-amp		channels	Vcc [V] min/max	Vio [mV] max	Iib [nA] max	Icc [μA] typ	GBP [MHz] typ	package
<b>TSV911</b> <b>TSV912</b> <b>TSV914</b>	Rail-to-rail Op-amp with CMOS input	1/2/4	2.5/5.5	1.5/4.5	0.010	780	8	SOT23-5L SO8 MiniSO8 TSSOP14 SO14
<b>TSV991</b> <b>TSV992</b> <b>TSV994</b>	Rail-to-rail Op-amp with CMOS input						20 (G≥3)	
<b>TS507</b>	Precision Rail-to-rail Op-amp	1	2.7/5.5	0.1	70	850	1.9	SOT23-5L SO8

## FEATURES

- Rail to rail output
- CMOS input
- 2.5V to 5.5V supply operation
- High merit factor **GBP/ICC**
  - 8 MHz – 780 $\mu$ A per amplifier 8Mhz
- 1pA (typ) input Bias Current

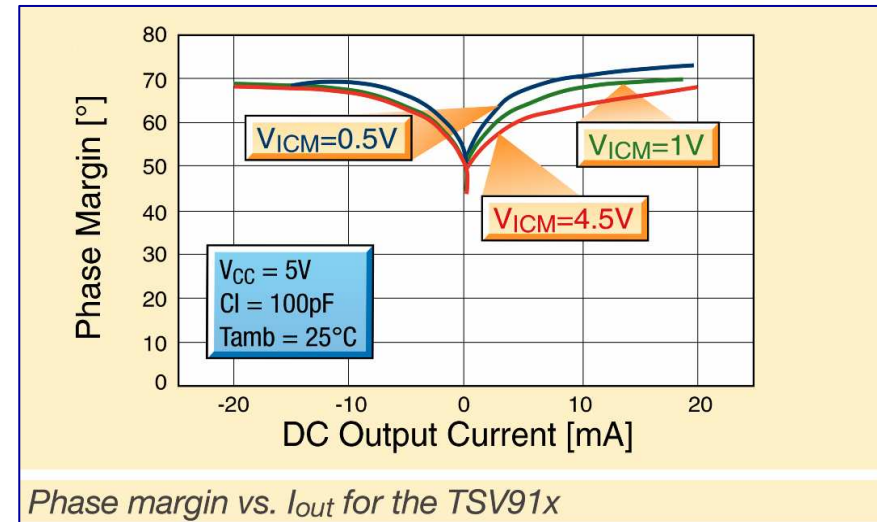

## APPLICATIONS

- Battery-powered applications
- Portable devices
- Sensor signal conditioning
- Medical instrumentation
- Active filtering, buffering



SOT23-5

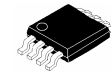

miniSO8



SO8



SO14



TSSOP14

## FEATURES

- Rail to rail input / output
- CMOS input
- 2.5V to 5.5V supply operation
- Very high slew rate & GBP
  - 20MHz for gain $\geq$ 3, CL=100pF
  - SR=10V/ $\mu$ s
  - I<sub>cc</sub>=780 $\mu$ A
- 1.5mV (max) input offset voltage
- 1pA (typ) input Bias Current

## APPLICATIONS

- Motor control
- Battery-powered applications
- Sensor signal conditioning
- Medical instrumentation
- Active filtering, buffering
- Instrumentation / factory automation

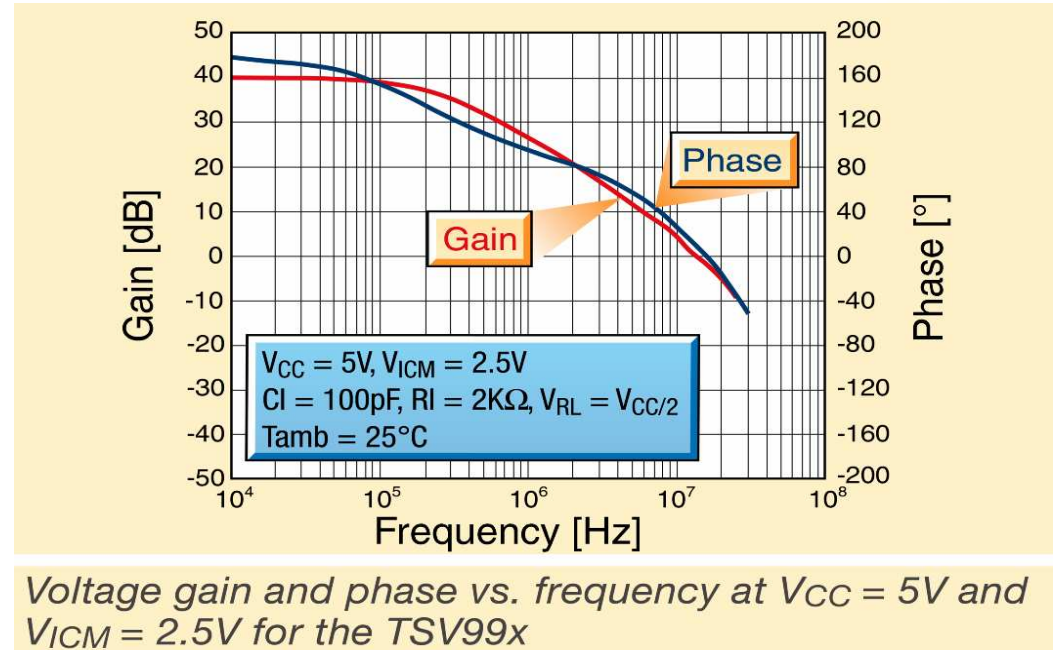

SO14



TSSOP14



SOT23-5



SO8

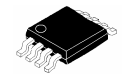

miniSO8

# Current sense amplifier



- The Current Sensing Amplifiers is **a new standard product family** introduced by ST in **2007**
- Different methodologies for current measurements
  - **transformer sensor (high power)**
  - **hall-effect sensor (high power)**
  - **shunt resistor**
    - **low-side shunt: can be done with a rail-to-rail operational amplifier chosen among standard linear IC's portfolio (example: TS507)**
    - **high-side shunt: new TSCxxx family**

# Introduction to current sensing

## Principle of operation

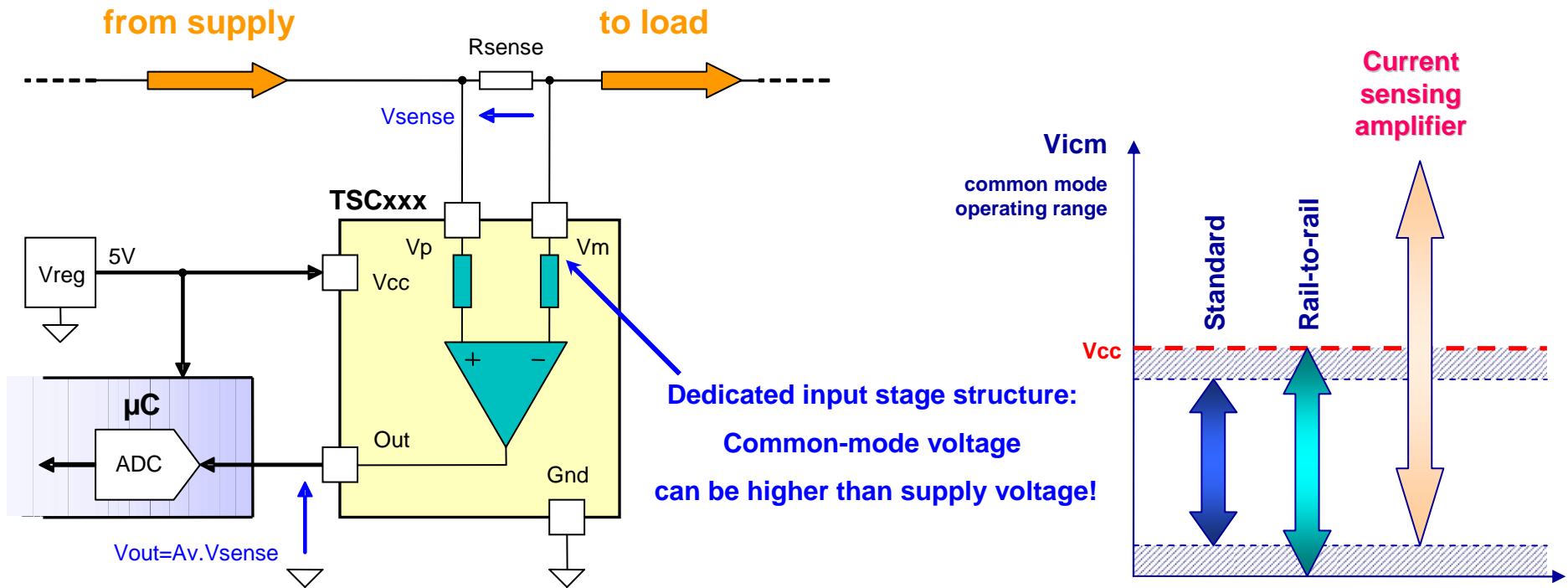

- current measured by a shunt resistor
- differential voltage accurate amplification
- output voltage is referenced to GND

# Introduction to current sensing

## How TSC101 is supplied?

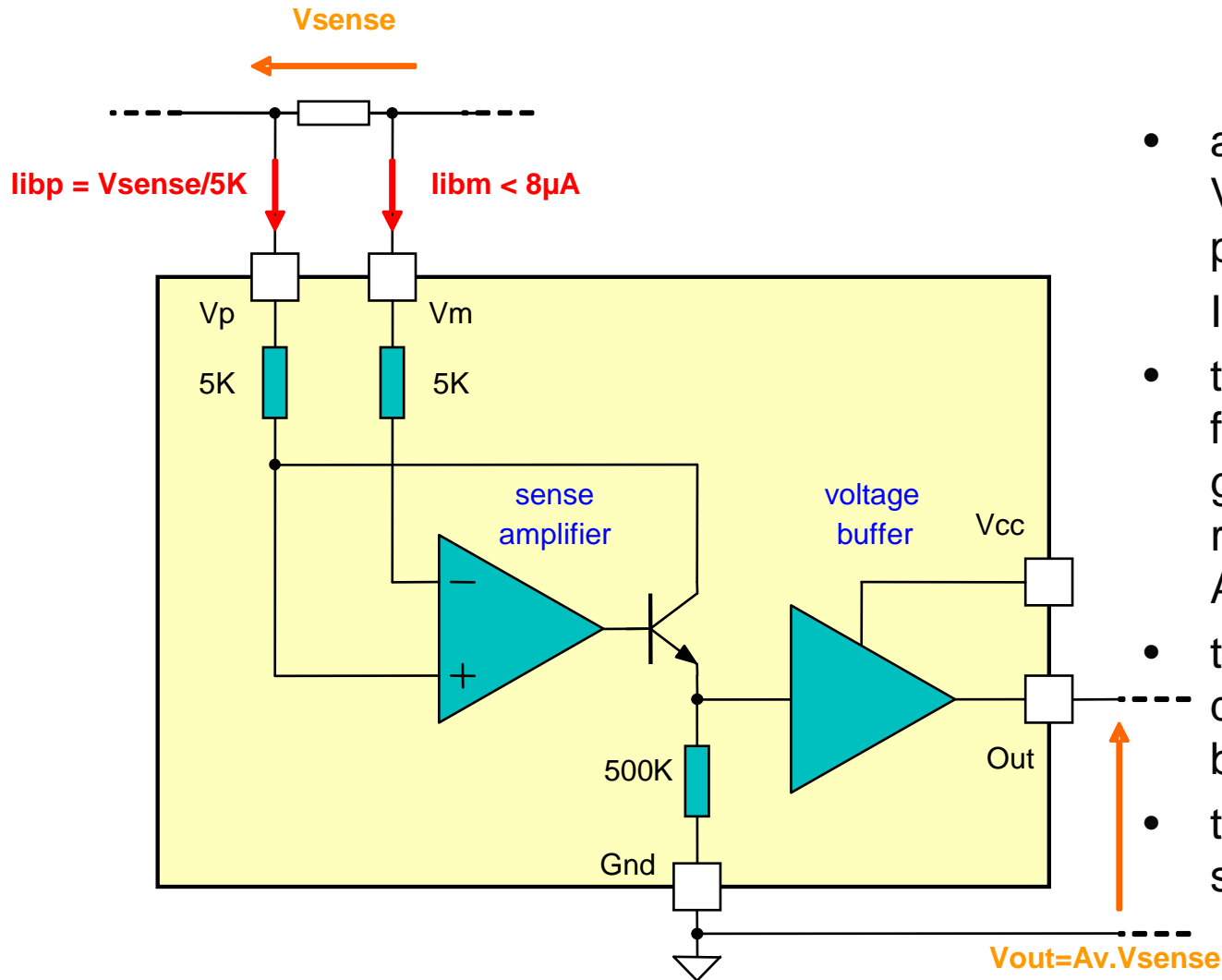

- a current proportional to  $V_{sense}$  is sunk into  $V_p$  pin:  
 $I_{bp} = V_{sense}/5K$
- the same current  $I_{bp}$  flows into a 500K ground-referenced resistor (gain  $A_v=100V/V$ )
- the resulting voltage is duplicated to output pin by a buffer
- the buffer amplifier is supplied by  $V_{cc}$

# TSC101 presentation

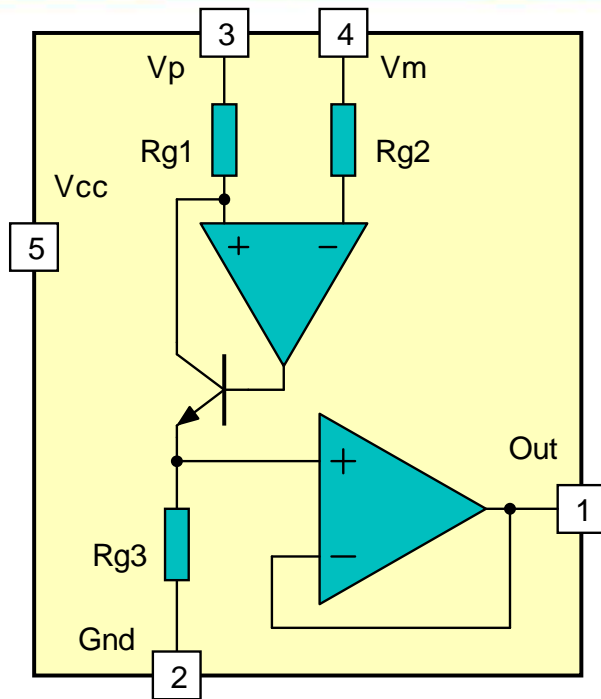

- Independent supply and input common-mode voltages
- Wide common-mode operating range: 2.8 to 30V
- Wide common-mode surviving range: -0.3 to 60V
- Wide supply voltage range: 4 to 24V
- Low current consumption:  $I_{cc\ max} = 300\mu A$
- Internally fixed gain: 20V/V, 50V/V or 100V/V
- Buffered output
- 2kV ESD protection

- BCD Technology (Bipolar / Cmos / Dmos)
- SOT23-5 package
- -40 to 125°C operating temperature range

- Automotive grade qualification:
  - PPAP done
  - PAT in Q1 2008
  - Hot Test Q3 2008

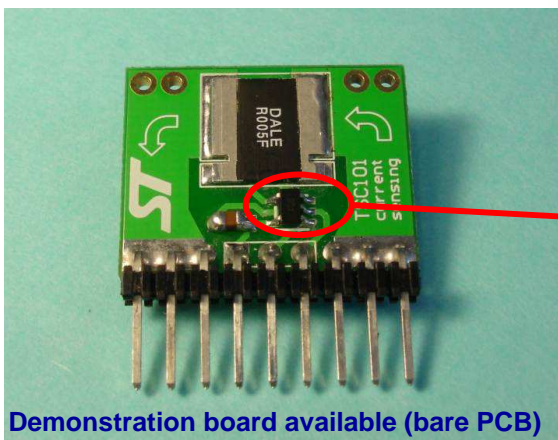

Demonstration board available (bare PCB)

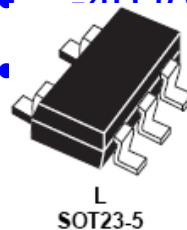

- **Standard linear**
  - Linear regulators
  - Comparators
  - Operational amplifier
  
- **Sensors**
  - **Temperature**
  - Proximity
  - Industrial I/O peripheral
  - MEMS

# TEMPERATURE SENSORS

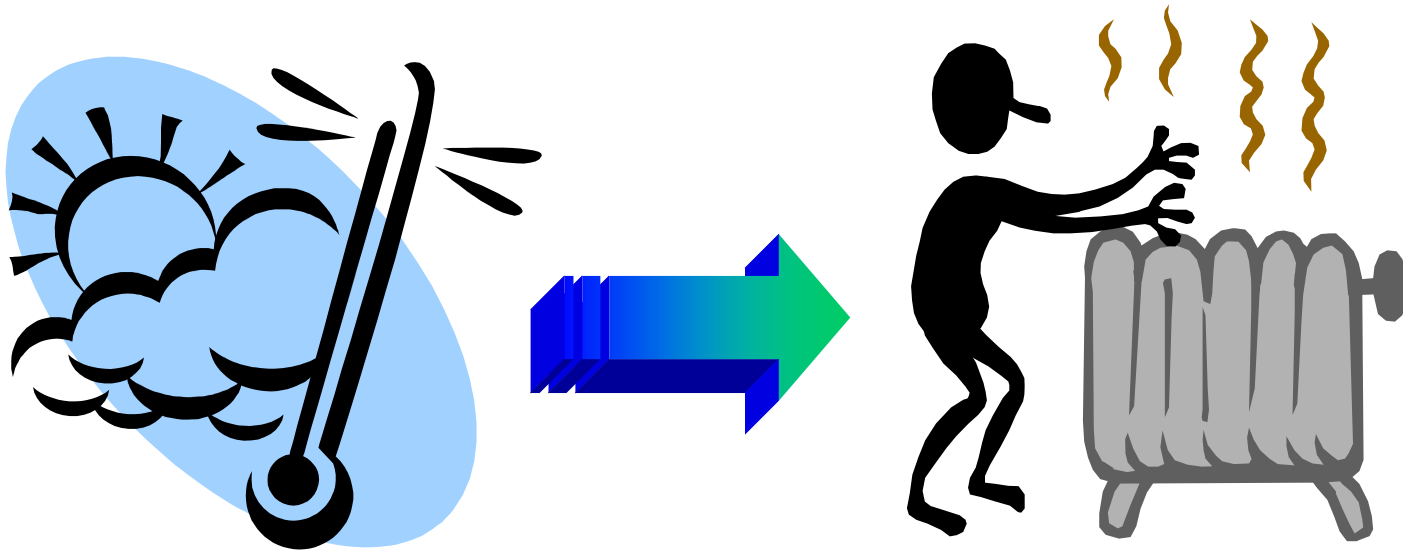

# TEMPERATURE SENSOR



ST has recently added to its existing family of precision analog temperature sensors and developed a new family of precision digital temperature sensors. Both types are suitable for use in a wide range of applications in market segments such as industrial, consumer, medical and computer.

The **analog** temperature sensors feature low power consumption and good linearity and can operate over a temperature range as wide as -55°C to +130°C.

The **digital** temperature sensors feature low power consumption, up to 12-bit resolution and can operate over a temperature range as wide as -55°C to +125°C.



# STML20 ANALOG TEMPERATURE SENSOR



**Ultra low POWER Analog temperature sensor available in ultra small mDFN package**

## Features

- **Analog temperature sensor:**
  - -55°C/+130°C :SC70 package
  - -40°C/+85°C : uDFN package
- **Supply voltage :**
  - 2.7 to 5.5V across -55°C/+130°C
  - 2.4 to 5.5V across -40°C/+130°C
- **Current max across all conditions : 8µA**
- **Accuracy:**
  - @ 25°C : +/- 1.5%
  - @ -55°C/+130°C : 2.5%
- **Ultra small uDFN package (1.3x1.0mm)**

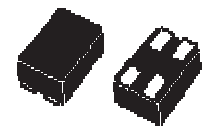
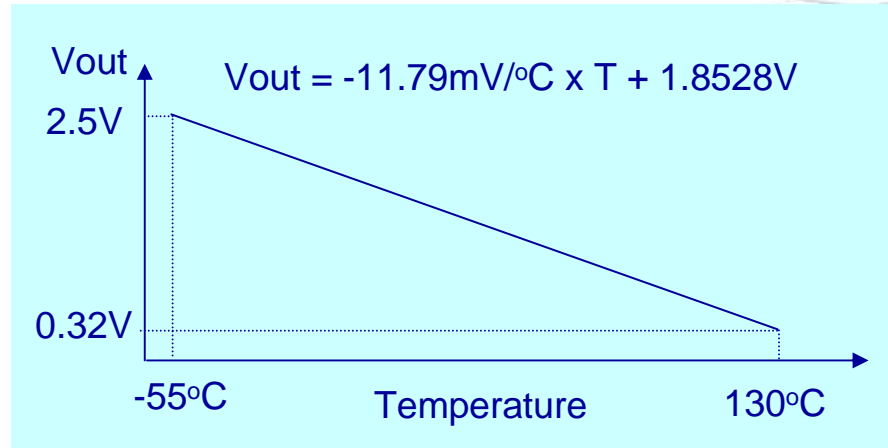

UDFN 4 Lead (DD)

Product Name	Description	Package
STLM20DD9F	Analog temperature sensor	uDFN
STLM20W87F	Analog temperature sensor	SC70

- **Standard linear**
  - Linear regulators
  - Comparators
  - Operational amplifier
  
- **Sensors**
  - Temperature
  - **Proximity**
  - Industrial I/O peripheral
  - MEMS

# PROXIMITY SENSORS



- **TDE0160 and TDA0161 proximity detectors.**
  - TDA0161 is a 2 wires detector housed in SO-8 or DIP-8 package.
  - TDE0160 is a 3 wires detector housed in SO-14 package, it is a double-output detector with adjustable hysteresis
- **Designed for ST's proximity detector devices, they can be coupled with any type of inductive, capacitive, ultrasonic or optical detectors.**
- **Metal body detection in home & building automation**

Part number	Technology	Package	V <sub>CC</sub> [V]	I <sub>CC</sub> supply [mA]	I <sub>out</sub> [mA]
TDA0161DP	Bipolar	DIP-8	4 to 35	12	10
TDA0161FP	Bipolar	SO-8	4 to 35	12	10
TDE0160FP	Bipolar	SO-14	4 to 36	1.2	40

## APPLICATION NOTES

- **AN1213: TDE1707 noise immunity, short circuit and reverse output protection characterization**
- **AN495: Effective filtering of TDE1707**

- **Standard linear**
  - Linear regulators
  - Comparators
  - Operational amplifier
  
- **Sensors**
  - Temperature
  - Proximity
  - **Industrial I/O peripheral**
  - MEMS

# CLT3-4B Current limited termination

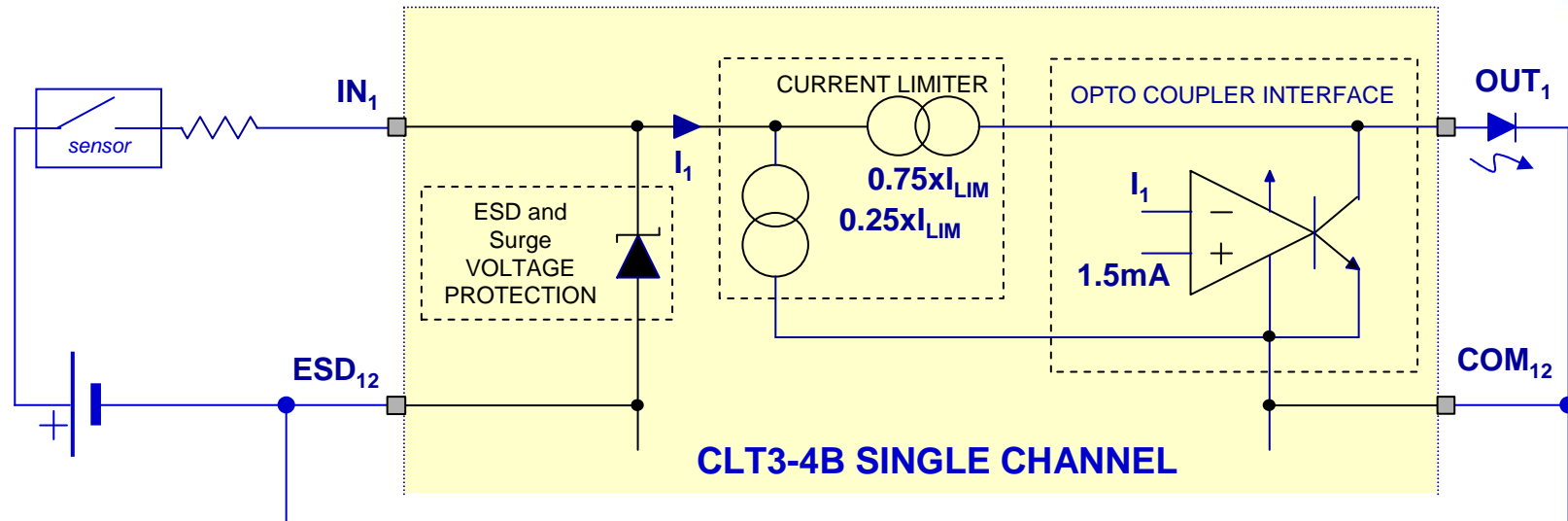

- CURRENT LIMITER
  - Current limiter :  $I_{LIM} = 3\text{mA}$
  - Meet IEC61131-2 type 1 & 3 input
  - Temperature compensated
- WIDE RANGE OPERATION
  - Input: - **30 to 35V** ( $R_I = 1.2\text{K}$ )
  - $V_{CC}$ : - 0.3 to 35V ( $R_C = 4.7\text{K}$ )
  - $T_{AMB}$ : - 25 to 85°C
- OPTO-COUPLER INTERFACE
  - Bypass opto-coupler for  $I_{IN} < 1.5\text{mA}$
  - Feed opto-coupler when  $V_I > 11\text{V}$
- INPUT PROTECTION
  - Voltage **surge** IEC61000-4-5, 1kV
  - **Burst** immunity IEC 61000-4-4, 4kV
  - **ESD** IEC 61000-4-2, 8kV
  - Input reverse polarity biasing

# CLT3-4B Current limited termination



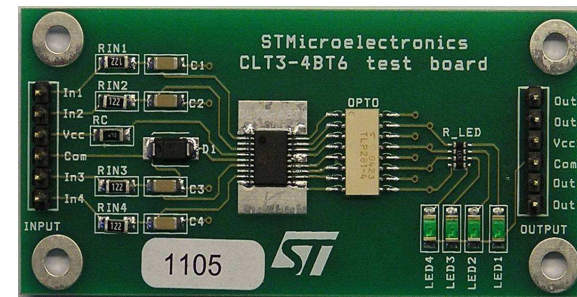
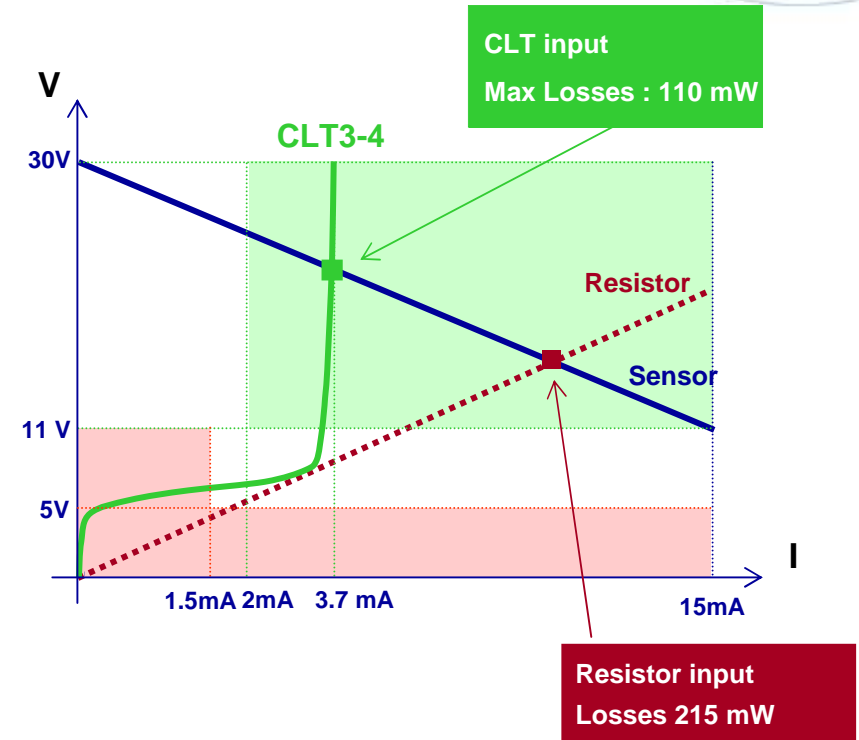

- REDUCED DISSIPATION
  - 50% to 67% in the full sensor chain
  - 35% to 67% in the module
- HIGHER DENSITY OF MODULE
  - SMD Thin TSSOP20 package
  - Compact for high integration
  - Low component count
- HIGHER RELIABILITY
  - Over-voltage protected
  - Immune to fast transient
  - Limited input current
- OPERATION INSENSITIVE TO
  - Sensor impedance
  - Voltage & temperature
  - Reverse polarity connection



# Current limited termination – key benefit



INPUT COUNT PER MODULE	16		32	
SOLUTION	ACTIVE CLT3	PASSIVE DISCRETE	ACTIVE CLT3	PASSIVE DISCRETE
CHANNEL DISSIPATION	0.11W	0.3W	0.11W	0.3W
MODULE DISSIPATION	1.77W	4.8W	3.6W	9.6W
CONCLUSION	FOR SAME INPUT COUNT, DIVIDE MODULE SIZE BY 2		FOR SAME MODULE SIZE, MULTIPLY BY 2 INPUT COUNT	
	 REDUCE COST		 INCREASE PERFORMANCE	

# PRODUCT PROFILING



CLT PRODUCT	CLT3-4B	PCLT-2A
IEC 61131-2 input	<b>Type 1 &amp; 3</b>	<b>Type 1, 2, 3</b>
Front End LED status	<b>No</b>	<b>Yes</b>
Output drive	<b>Isolated</b>	<b>Isolated or un-isolated</b>
	<b>Opto transistor</b>	<b>Opto transistor CMOS compatible</b>
APPLICATION	<b>High Input count module PLC Distributed I/O</b>	<b>Low Input count module Proxy Sensor interface Distributed I/O</b>
Channel count	<b>4</b>	<b>2</b>
Input current reg	<b>2.8mA</b>	<b>Adj: 2.5 to 7.5mA</b>
Surge level	<b>1kV</b>	<b>Type 1 &amp; 3: 1kV Type 2 : 0.5kV</b>
ESD Level	<b>8kV</b>	<b>15kV</b>
Package	<b>TSSOP20 (14+6)</b>	<b>TSSOP14 exposed pad</b>

- **Standard linear**
  - Linear regulators
  - Comparators
  - Operational amplifier
  
- **Sensors**
  - Temperature
  - Proximity
  - Industrial I/O peripheral
  - **MEMS**

- Micro Electro Mechanical System Technology **exploits the mechanical properties of silicon to create movable structures that are able to sense acceleration or vibration in each direction.**
- *Applications in home & building automation:*
  - *User interfaces*
  - *Anti-theft systems*
  - *Remote device control*

# MEMS Portfolio



**PERFORMANCE**  
High

**High Performance  
Digital Family**

**Small Size Smart  
Digital Family**

**High Performance  
Analog Family**

**Small Size 3-axis  
Analog Family**

**Small Size 2-axis  
Analog Family**

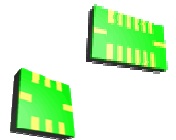

**SIZE**  
Small

**All product supported by Evaluation Kits**

## A world of applications

Mobile phones  
and PDAs



Portable  
media players



Toys and  
games



Laptop and  
pocket PCs



Sports and  
health



Audio and  
video devices



Automotive



Home appliances



Industrial  
appliances



Home security  
systems

# MEMS: analog output



## Analog output – key features

- Analog output with additional multiplexer output
- 2- and 3-axis
- Selectable full scale: +/- 2 g or +/- 6 g
- Power-down mode
- Resolution better than 0.5 mg @ 100 Hz
- <1 mA current consumption in normal mode
- <10  $\mu$ A current consumption in power-down mode
- Embedded self test
- Temperature range -40 to +85 °C
- Factory trimmed parameters
- High shock survivability: 10,000G for 0.1 ms
- High thermal stability
- High lifetime stability
- LGA packages available

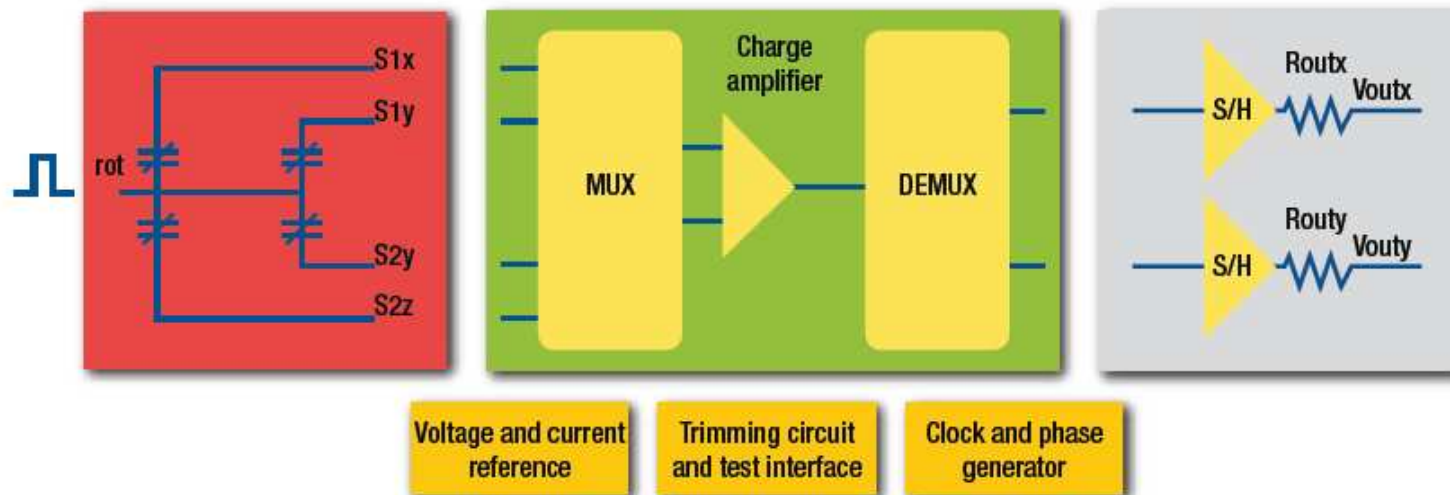

# MEMS: digital output



## Digital output – key features

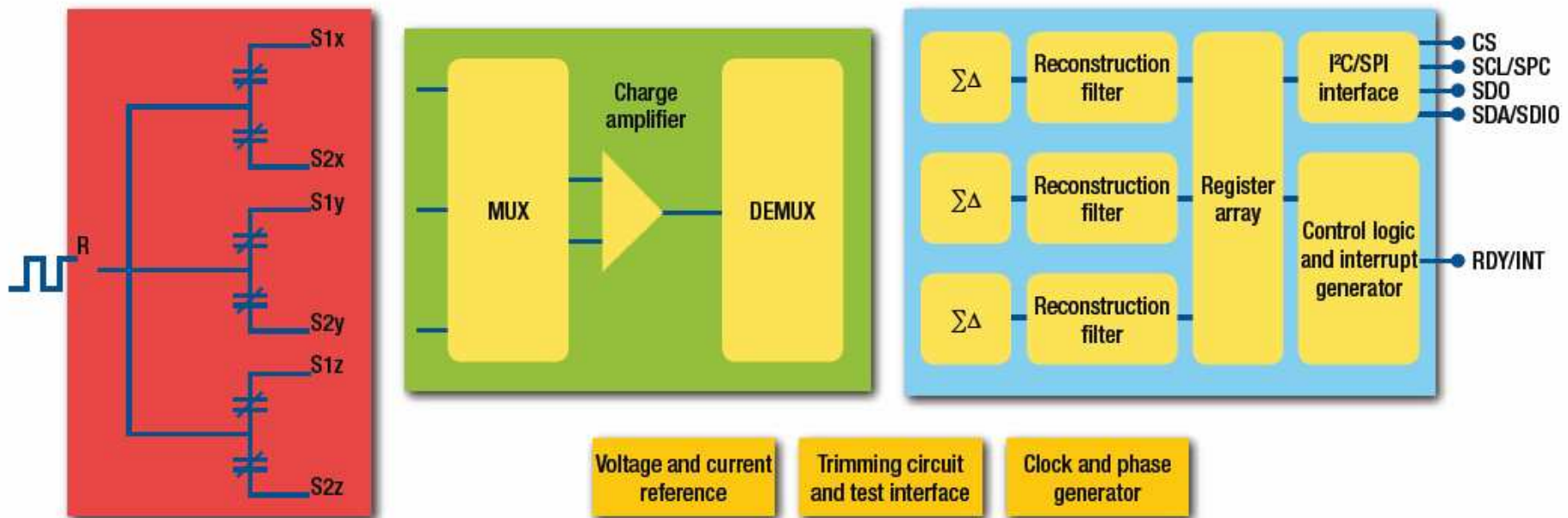

- MEMS sensor and interface chip in one package
- 2- and 3-axis
- Direction detection
- Click and double click recognition
- Embedded high-pass filter
- I<sup>2</sup>C/SPI output
- Programmable bandwidth and data rate
- Resolution better than 1 mg
- Power-down mode
- 2 independent, programmable interrupt pins
- Wake-up/free-fall interrupt signal with programmable thresholds
- Temperature range -40 to +85 °C
- Factory trimmed parameters
- High shock survivability: 10,000G for 0.1 ms
- High thermal stability
- High lifetime stability
- LGA and QFN packages available



# MEMS Portfolio

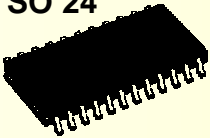

**Low Cost Package**

	SO 24 	QFN 	LGA 		
<b>2-axis</b>	<b>LIS2L02AS4</b> Analog, PD 2g/6g FS	<b>LIS2L02AQ3</b> Analog, PD 2g/6g FS, QFN-44	<b>LIS2L02AL</b> Analog, 2g FS LGA-8, 5x5x1.5 mm		<b>Analog Output</b>
			<b>LIS2L06AL</b> Analog 2g/6g FS, LGA-8 5x5x1.5 mm	<b>LIS244AL*</b> Analog, 3.5g FS LGA 16, 4x4x1.5 mm	
<b>3-axis</b>	<b>LIS3L02AS4</b> Analog, PD 2g/6g FS	<b>LIS3L02AQ3</b> Analog, PD 2g/6g FS, QFN-44	<b>LIS3L02AL*</b> Analog 2g FS LGA-8, 5x5x1.5 mm	<b>LIS302ALB</b> Analog 2g FS LGA-14, 3x5x0.9 mm	<b>Digital</b>
		<b>LIS3L02AQ5</b> Analog, PD 2g/6g FS, QFN-44	<b>LIS3L06AL</b> Analog 2g/6g FS LGA-8, 5x5x1.5 mm	<b>LIS302ALK</b> Analog 2g FS LGA-14, 3x5x0.9 mm	
		<b>LIS3LV02DQ</b> SPI/I <sup>2</sup> C, PD 2g/6g FS, QFN-28	<b>LIS3LV02DL*</b> SPI/I <sup>2</sup> C, PD, 2g/6g FS, LGA16 7.5x4.4x1 mm	<b>LIS302DL*</b> SPI/I <sup>2</sup> C, PD, 2INT 2g/8g FS, LGA-14 3x5x0.9 mm	
<b>Sensors</b>			<b>MEMS</b>		

# Evaluation Kit Program



STEVAL-MKI001V1	<b>MEMS Analog Output Evaluation Board based on LIS3L02AS4 (EK3L02AS4)</b>
STEVAL-MKI002V1	<b>MEMS Analog Output Evaluation Board based on LIS3L02AL (EK3L02AL)</b>
STEVAL-MKI003V1	<b>MEMS Analog Output Evaluation Board based on LIS3L02AQ3 (EK3L02AQ3)</b>
STEVAL-MKI004V1	<b>MEMS 3-Axis <math>\pm 2g/\pm 6g</math> Digital Output Low Voltage Linear Accelerometer Evaluation Board based on LIS3LV02DQ (EK3LV02DQ)</b>
STEVAL-MKI005V1	<b>MEMS 3-Axis <math>\pm 2g/\pm 6g</math> Digital Output Low Voltage Linear Accelerometer Evaluation Board based on LIS3LV02DL (EK3LV02DL)</b>
STEVAL-MKI006V1	<b>MEMS 3-Axis <math>\pm 2g/\pm 8g</math> Digital Output Low Power Linear Accelerometer Evaluation Board based on LIS302DL (EK302DL)</b>
STEVAL-MKI007V1	<b>MEMS Analog Output Low Power 3-Axis linear accelerometer based on LIS302ALB (EK302ALB)</b>
STEVAL-MKI008V1	<b>MEMS Analog Output Low Power 3-Axis linear accelerometer based on LIS302ALK (EK302ALK)</b>
STEVAL-MKI009V1	<b>LIS3LV02DL Adapter Board designed to be plugged into a standard DIL 20 socket</b>
STEVAL-MKI010V1	<b>LIS3L02AS4 Adapter Board designed to be plugged into a standard DIL 20 socket</b>
STEVAL-MKI011V1	<b>LIS302ALB Adapter Board has been designed to be plugged into a standard DIL 20 socket.</b>
STEVAL-MKI012V1	<b>MEMS Analog Output Evaluation Board based on LIS3L06AL (EK3L06AL)</b>