

Low Supply Voltage Type

2560TK



Features

- Leadless type clock oscillator which fits highly dense mounting, with light & small demand, surface mounting.
- IR reflow, automatic mounting are applicable.
- Frequency range : 1.8MHz~67MHz.
- Stand-by function for output : Tri-state output.
- Static electricity proof package with tape & reel available.

RoHS Compliant
Directive 2002/95/EC

Absolute Maximum Rating
Supply Voltage (V_{DD}) $-0.5\sim+7.0V$ DC
Storage Temperature Range $-55\sim+125^{\circ}C$

Item		Model		
Output Level		2560TK		
		C-MOS		
Frequency Range	(MHz)	$1.8 \leq F \leq 32$	$32 < F \leq 50$	$50 < F \leq 67$
Frequency Stability	($\times 10^{-6}$)	± 100		
Operating Temp. Range	($^{\circ}C$)	$-10 \sim +70$		
Supply Voltage (V_{DD})	(V)	3.3 ± 0.3		
Current Consumption	(mA) +5V DC, 25 $^{\circ}C$	10 (max)	15 (max)	18 (max)
V_{OL} max/ V_{OH} min	(V)	$0.1V_{DD}/0.9V_{DD}$ $I_{OL}=2mA$ $I_{OH}=-2mA$		
T_r max/ T_f max	(ns)	6/6 (0.1 V_{DD} ~0.9 V_{DD})		
Duty Cycle	(%)	45~55 (at +1/2 V_{DD})		40~60 (at +1/2 V_{DD})
Fanout (gate)	C_L (pF)	15		
Stand-by Function	Tri-state	Yes		

2560TK Outline

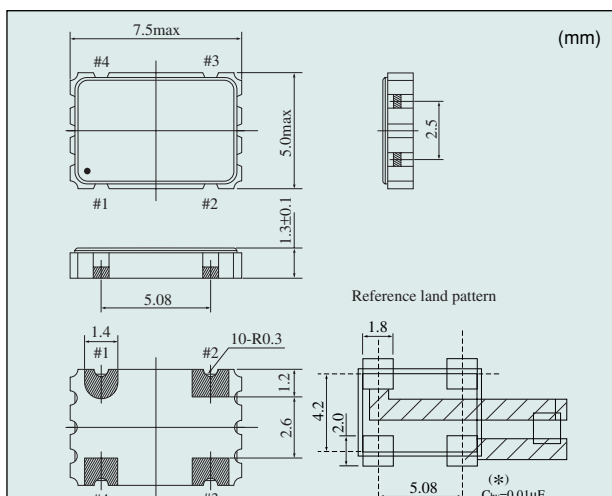

PAD No.	Connection
# 1	STAND-BY
# 2	GND
# 3	OUTPUT
# 4	V_{DD}

Output Wave <C-MOS>

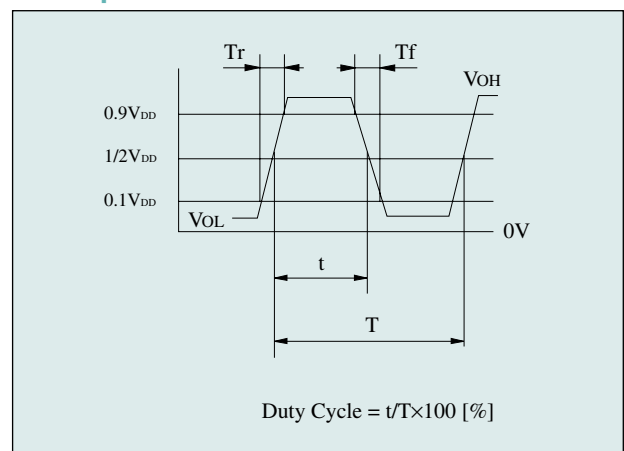

Stand-by Function <Tri-state>

# 1 input	# 3 output
H level (+0.7 V_{DD} min) or open	Operating
L level (+0.3 V_{DD} max)	High impedance

Handling Cautions (2500 series)

Examples for soldering conditions

(Infra-red ray reflow soldering)

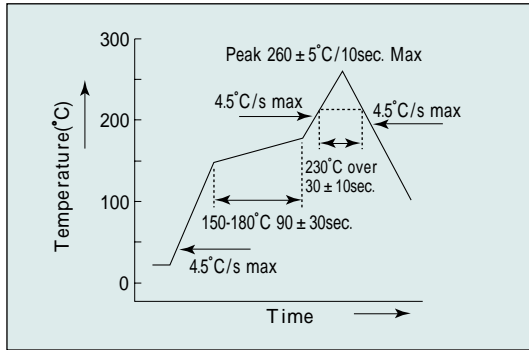

● Soldering

To avoid product damage during soldering, please follow either below reflow conditions (a) or (b).

- (a) Temperature : 260°C (max)
Duration : 10 seconds (max)
- (b) Temperature : 230°C (max)
Duration : 80 seconds (max)

● Cleaning

Basically, the 2500 series can be cleaned by ultrasonic wave. However, in some cases, during ultrasonic wave cleanings, internal design may be damaged. Please check conditions carefully beforehand.

● Marking resistance to solvents

The markings withstand 30 minutes soaking in Alcohol.

If conditions are more severe than above mentioned, please check carefully beforehand.

● Others

The 2500 series are C-MOS products. Careful handling (same as with C-MOS IC) is needed to avoid electrostatic problems.

Incorrect pin connection can cause problems.

Please make sure to connect correctly as below.

- #2 terminal → GND
- #4 terminal → V_{DD}

Taping Dimensions (2500 series)

Taping method

Quantity	Taping method
1~499	Vinyl bag packaging
500~1999	Taping
2000 ~	Taping & Reel

Tape

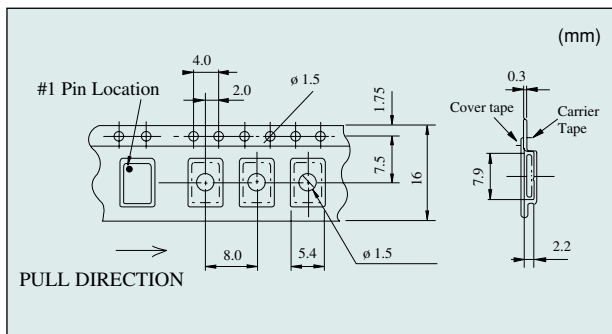

2000 pieces/reel are boxed and shipped with the taping method as shown above

Reel

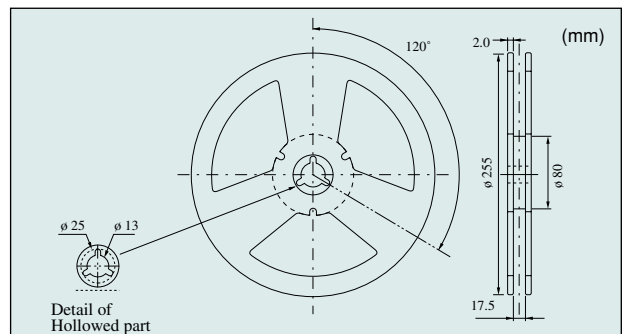

*Note The Packaging method shown above is only for large orders. For small orders, or for samples, the packaging form is different according to the requested quantity .

CRYSTAL CLOCK OSCILLATORS

2500 SERIES WARRANTY CLAUSE

No.	Item	Condition	Specification
1	Thermal Shock Test	1 Cycle: -55°C (15minutes)~ $+125^{\circ}\text{C}$ (15minutes) Number of Cycle : 5 cycles in gas phase	(1)
2	Vibration Test	10~55Hz, 1.5mm (Peak to Peak) 55~2000Hz, 196m/s^2 Sweep time 6 Hours (3 directions, 2H each)	(1)
3	Drop Test	Drop Height: 75 cm, 3 drops onto hard wooden board	(1)
4	Soldering. Resistance	Test Condition Soaking in the soldering bath at $+260^{\circ}\text{C}\pm 5^{\circ}\text{C}$ for 20 seconds 2 times each or Soaking in the soldering bath at $+230^{\circ}\text{C}\pm 5^{\circ}\text{C}$ for 180 seconds 2times each	(1)
5	Soldering Test	Test Condition: Soaking in the soldering bath at $+235^{\circ}\text{C}\pm 5^{\circ}\text{C}$ for 2 ± 0.5 seconds	(2)
6	Air Tightness	5minutes immersion in Fluorinert at $125^{\circ}\text{C}\pm 5^{\circ}\text{C}$	(3)
7	Solvent Resistance	Soaking in alcohol for 30 minutes	(4)

(1) After the tests mentioned above, the electrical specifications are satisfied.
The electrical specifications are Tr/Tf, V_{OL}/V_{OH} , Duty Cycle.
(2) More than 90% of Lead or Pad should be covered by solder.
(3) No bubbles should be observed.
(4) The markings are not faded out.

2500 SERIES MARKING

Marking frequency digits differs according to marking space available.
Please refer to below.

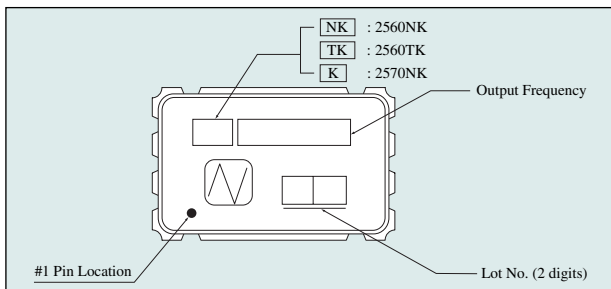

2500 Series:

- Including decimal point, 6 digits are marked.
[EX] 14.31818MHz → 14.318