



NIHON DEMPA KOGYO CO., LTD  
TUNING FORK CRYSTAL SPECIFICATIONS



Date: January 18,2007

THIS SPECIFICATION SHEET IS PROVIDED TO:

For specifying specifications of following product:

350039-32.768KHz  
(NDK Part Number)

\_\_\_\_\_  
(Your Part Number)

Prepared By:

CONFIRMED BY:

Checked By:

For future reference, we thank you to confirm the specifications and send one copy back to us.



NIHON DEMPA KOGYO CO., LTD  
TUNING FORK CRYSTAL SPECIFICATIONS



● ELECTRICAL PARAMETERS

ELECTRICAL CHARACTERISTICS :

<u>Parameter</u>	<u>Symbol</u>	<u>Condition</u>	<u>Specifications</u>	<u>Unit</u>
1.Nominal Frequency	Fo	At 25°C	32.768	KHz
2.Frequency Tolerance	$\Delta F/Fo$	At 25°C	+/- 20	ppm
3.Tolerance Stability Over Temp. Range	Tc		$(-3.5\pm 1.0)\times 10^{-8}/^{\circ}C^2$	ppm
4.Operating Temp. Range	Topr		-40°C to +85°C	°C
5.Storage Temp. Range	Tstg		-55°C to +125°C	°C
6.Load Capacitance	CL		12.5	pF
7.Equivalent Series Resistance	R1		50 Max.	kohm
8.Shunt Capacitance	C0		1.0 Typ.	pF
9.Motional Capacitance	C1		2.2 Typ.	fF
10.Drive Level	DL		1.0 Max.	uW
11.Aging	Fa	At 25°C, Per Year	+/-5.0 Max	ppm

● OUTLINE DIMENSIONS (UNIT:MM)

**IT-CS2-004**

Dimension [mm]

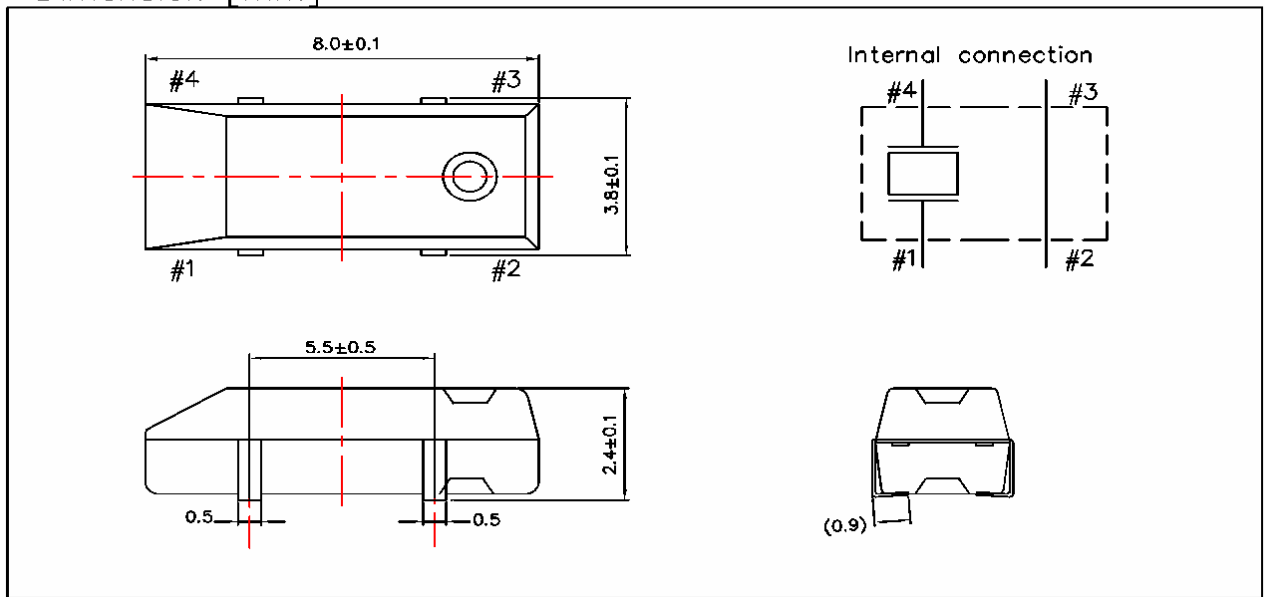

Solder PAD Layout [mm]

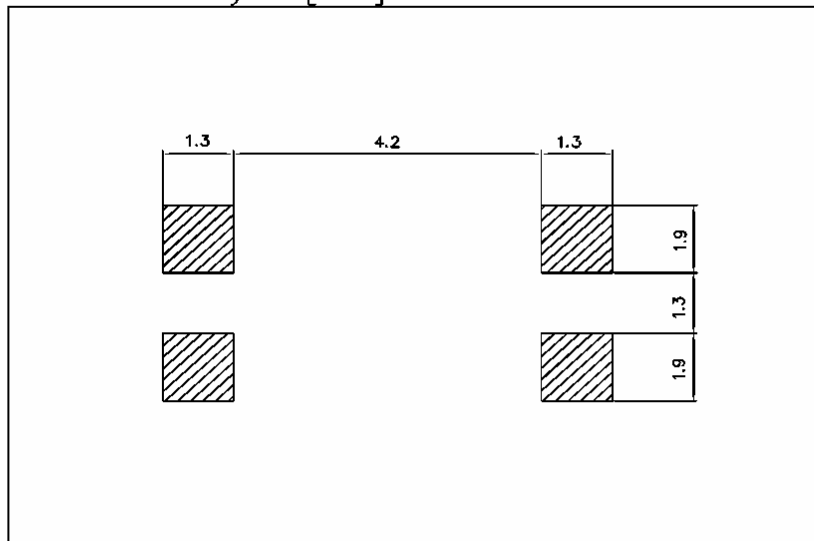

- PACKAGE

**IT-MK-CS2-005**

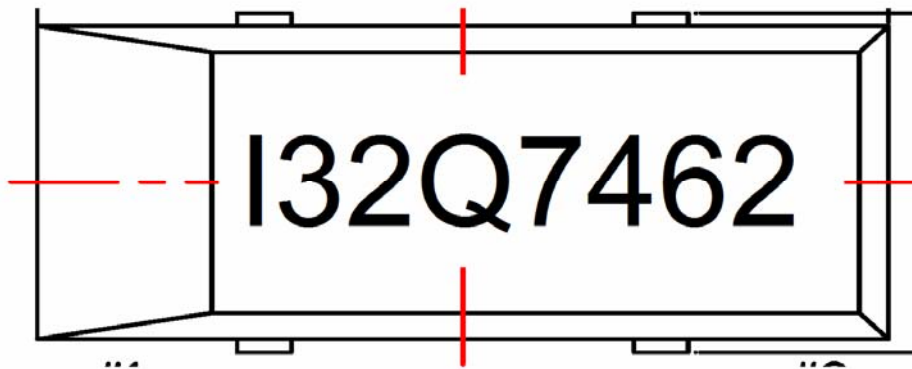

**Example for the marking**  
**Marking: I32Q7462 (8 Digits)**

- I = FIXED**
- 32 = 32.768 KHZ (FIXED)**
- Q = 12.5 PF**
- 74 = PRODUCTION CODE (FIXED)**
- 6 = YEAR CODE**
- 2 = MONTH CODE**

● PACKAGE

## IT-PK-CS2-006

### Carrier tape

Tolerance  $\pm 0.2$

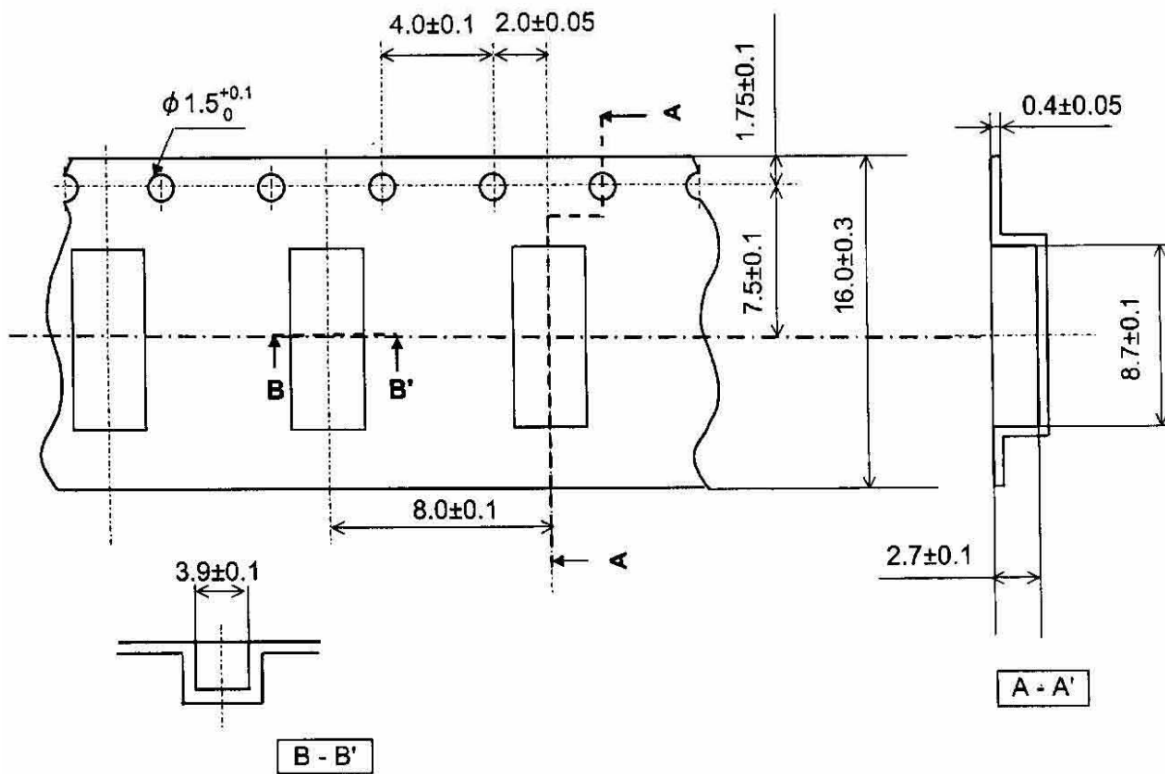

## Taping reel

Quantity per reel : 3,000pcs./ for a reel

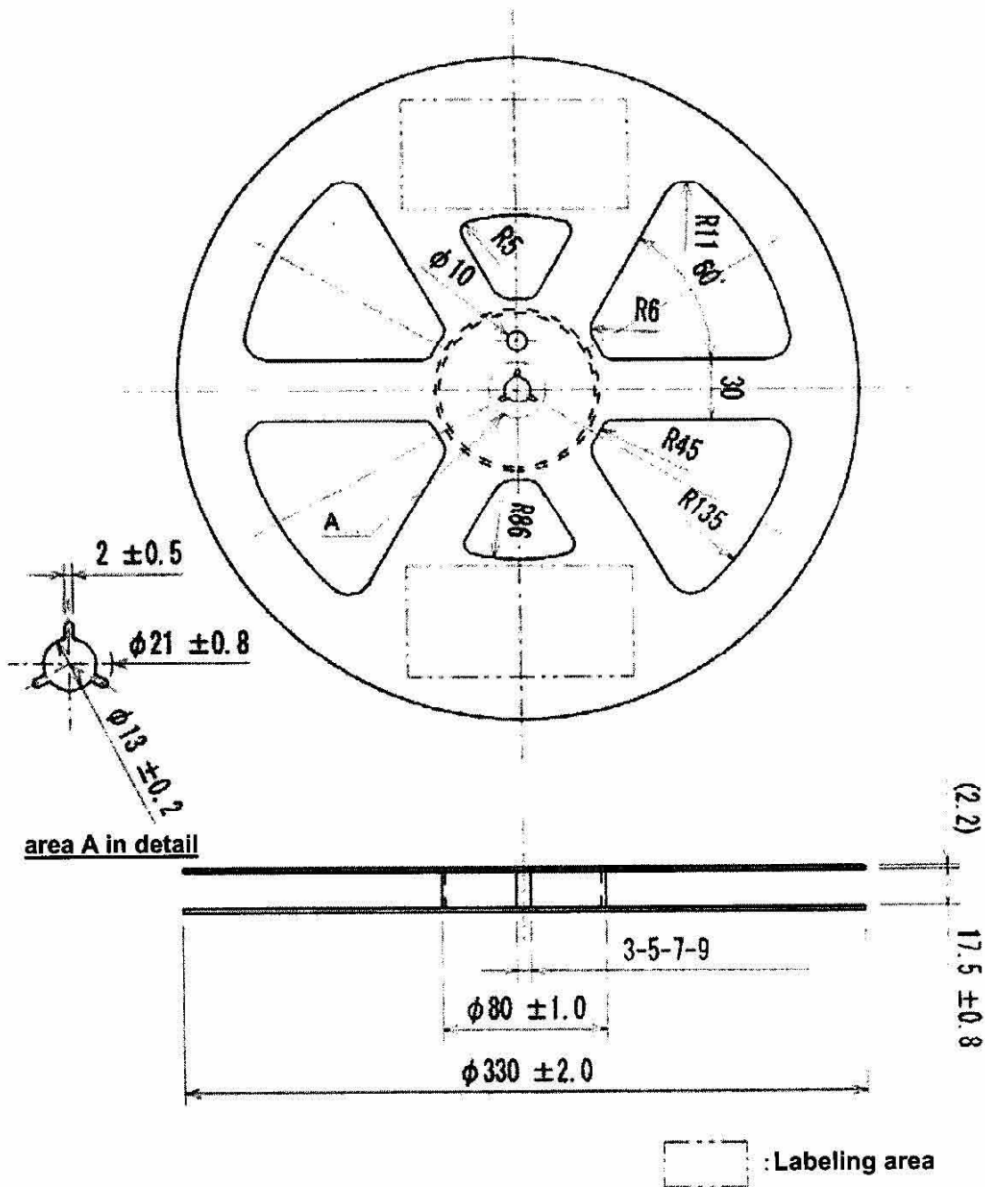

Unit : mm

## IT-RL-CS2-005

NO	Item	Specifications	Conditions
1	High temperature storage	$\Delta f/f = \pm 10 \times 10^{-6}$	After storage under 85°C for 500 hrs, measure at room temperature. *1
2	Low temperature storage	$\Delta f/f = \pm 10 \times 10^{-6}$	After storage under -40°C for 500 hrs, measure at room temperature. *1
3	High temperature and high humidity storage	$\Delta f/f = \pm 10 \times 10^{-6}$	After storage under 60°C $\pm$ 2°C, 90 to 95% RH for 500 hrs, measure at room temperature. *1
4	Thermal shock resistance	$\Delta f/f = \pm 10 \times 10^{-6}$	Measured at room temperature after 20 cycles. -25°C $\leftrightarrow$ +80°C for 30 minutes. *1
5	Mechanical shock resistance	$\Delta f/f = \pm 5 \times 10^{-6}$	Measure after free drop of the RESONATOR three times from the height of 75cm onto a wooden board *2
6	Vibration resistance	$\Delta f/f = \pm 5 \times 10^{-6}$	Amplitude 1.5mm and 10~60Hz with cycle time 2~3 minutes in 3 direction ( X,Y, and Z axis)each for 2 hrs. *2
7	IR Reflow	$\Delta f/f = \pm 5 \times 10^{-6}$	Measure after 1 time reflow under reflow profile *1

**Note:**

1. The above tests no.1 to 7 must be conducted in dependently (not sense tests)
2. \*1:Measure after 24 hours soak at room temperature
3. \*2:Measure after 2 hours soak at room temperature
4. R1 is 65Ωmax. after the each above tests.